

## Abbruchbagger Volvo EC 380 D HDR



Tieflöffelausrüstung 6,45m - Stiel 3,20m 2,10 m<sup>3</sup>  
Abbruchausrüstung 21m Höhe  
Kettenplatte 600mm – verstellbarer Unterwagen 3,00m - 4,00m  
Vollautomatische Schnellwechsellplatte OilQuick OQ80 + OQ 70/55

### Mögliche Anbaugeräte Kurzausrüstung – OQ80

Schremmhammer AtlasCopco HB2200 2200kg  
Schremmhammer AtlasCopco HB3000 3000kg  
Sortiergreifer Wimmer SG06  
Betonzange Wimmer Topcut800  
Betonzange Wimmer CutCroco900

### Mögliche Anbaugeräte Abbruchausrüstung- OQ 70/55

Schremmhammer Wimmer W 550 1200kg  
Sortiergreifer Wimmer SG03  
Betonzange Wimmer Topcut 550

# SPECIFICATIONS.

## WORKING RANGES & DIGGING FORCES

### EC380DHR demolition machine with 3-piece demolition boom

Description	Unit	EC380DHR Undercarriage, fixed (Standard)
A Maximum pin height	mm	21 030
B Maximum pin reach	mm	13 500
Maximum tool weight	t	2.5
Operating angle	°	20

Description	Unit	EC380DHR Undercarriage hydraulically retractable
A Maximum pin height	mm	21 070
B Maximum pin reach	mm	13 500
Maximum tool weight	t	3
Operating angle	°	20

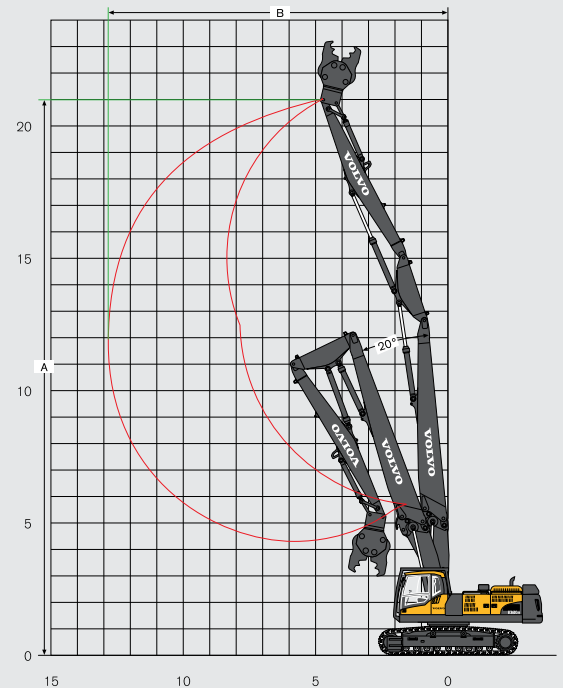

### EC480DHR demolition machine with 3-piece demolition boom

Description	Unit	EC480DHR Undercarriage, fixed
A Maximum pin height	mm	27 245
B Maximum pin reach	mm	15 840
Maximum tool weight	t	2.5
Operating angle	°	15

Description	Unit	EC480DHR Undercarriage mechanically retractable
A Maximum pin height	mm	27 355
B Maximum pin reach	mm	15 840
Maximum tool weight	t	2.5
Operating angle	°	15

Description	Unit	EC480DHR Undercarriage hydraulically retractable
A Maximum pin height	mm	27 355
B Maximum pin reach	mm	15 840
Maximum tool weight	t	3
Operating angle	°	15



## WORKING RANGES & DIGGING FORCES

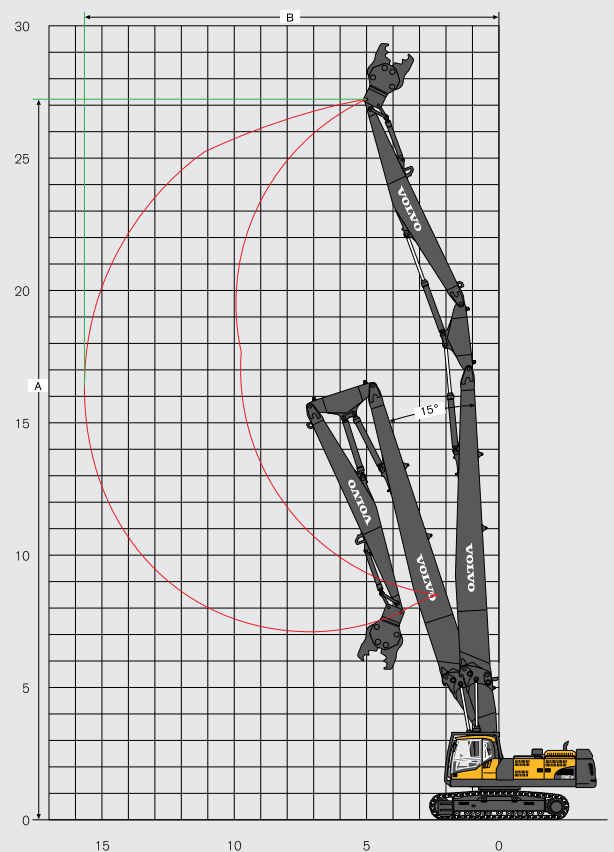

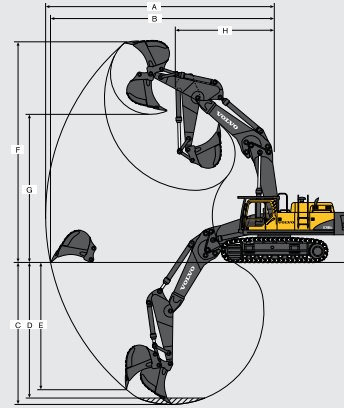
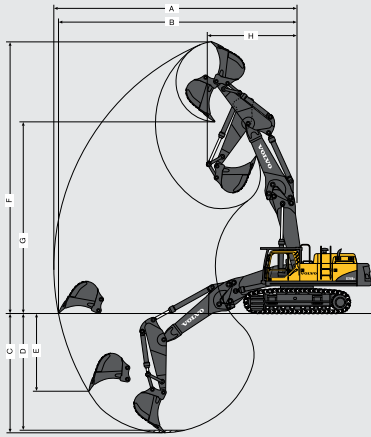
### Working ranges of demolition machines with straight boom\*

		Unit	EC380DHR		EC480DHR		EC700CHR		
Boom			Straight boom 6.8 m		Straight boom 7.5 m		Straight boom 8.3 m		
Arm			3.2 m	3.9 m	3.35 m	3.9 m	2.9 m	3.55 m	4.2 m
	Bucket tip radius	mm	1 880	1 880	1 936	1 936	2 150	2 150	2 150
A	Maximum digging reach	mm	11 890	12 570	12 790	13 310	13 300	13 890	14 520
B	Maximum digging reach on ground	mm	11 685	12 375	12 560	13 090	13 050	13 650	14 290
C	Maximum digging depth	mm	5 810	6 510	6 430	6 985	6 550	7 140	7 790
D	Maximum digging depth (2.4 m level)	mm	5 660	6 380	6 290	6 855	6 400	7 000	7 670
E	Maximum vertical wall digging depth	mm	4 265	4 780	3 345	3 745	4 980	5 570	6 080
F	Maximum cutting height	mm	13 555	14 150	13 895	14 265	14 890	15 290	15 790
G	Maximum dumping height	mm	9 800	10 400	10 070	10 445	10 620	11 040	11 530
H	Minimum front swing radius	mm	3 260	3 590	3 975	3 940	4 510	4 640	4 910

### Digging forces of demolition machines with straight boom\*

		Unit	EC380DHR		EC480DHR		EC700CHR		
Boom			Straight boom 6.8 m		Straight boom 7.5 m		Straight boom 8.3 m		
Arm			3.2 m	3.9 m	3.35 m	3.9 m	2.9 m	3.55 m	4.2 m
	Bucket tip radius	mm	1 880	1 880	1 936	1 936	2 150	2 150	2 150
	Breakout force-bucket (Normal/Power boost) ISO	kN	197/214	197/214	241/263	263/281	313/342	314/344	314/344
	Tearout force-arm (Normal / Power boost) ISO	kN	161/175	140/153	197/215	176/192	289/326	261/285	233/255
	Rotation angle, bucket	°	177	177	183	183	173	173	173

### Working ranges of demolition machines with bent boom\*

		Unit	EC380DHR		EC480DHR		EC700CHR		
Boom			Bent boom 6.5 m		Bent boom 7.0 m		Bent boom 7.7 m		
Arm			3.2 m	3.9 m	3.35 m	3.9 m	2.9 m	3.55 m	4.2 m
	Bucket tip radius	mm	1 880	1 880	1 936	1 936	2 150	2 150	2 150
A	Maximum digging reach	mm	11 320	11 970	12 070	12 560	12 500	13 050	13 650
B	Maximum digging reach on ground	mm	11 105	11 765	11 830	12 330	12 230	12 790	13 400
C	Maximum digging depth	mm	7 020	7 720	7 695	8 245	7 740	8 390	9 040
D	Maximum digging depth (2.4 m level)	mm	6 870	7 590	7 550	8 115	7 590	8 260	8 920
E	Maximum vertical wall digging depth	mm	5 730	6 320	5 080	5 480	6 560	6 760	7 380
F	Maximum cutting height	mm	11 500	11 870	10 990	11 140	12 180	12 250	12 520
G	Maximum dumping height	mm	7 985	8 365	7 525	7 690	8 370	8 600	8 870
H	Minimum front swing radius	mm	3 360	3 710	5 070	5 040	5 500	5 360	5 370

### Digging forces of demolition machines with bent boom\*

		Unit	EC380DHR		EC480DHR		EC700CHR		
Boom			Bent boom 6.5 m		Bent boom 7.0 m		Bent boom 7.7 m		
Arm			3.2 m	3.9 m	3.35 m	3.9 m	2.9 m	3.55 m	4.2 m
	Bucket tip radius	mm	1 880	1 880	1 936	1 936	2 150	2 150	2 150
	Breakout force-bucket (Normal/Power boost) ISO	kN	197/214	197/214	241/285	263/304	313/342	314/344	314/344
	Tearout force-arm (Normal / Power boost) ISO	kN	161/175	140/153	197/215	176/192	289/326	261/285	233/255
	Rotation angle, bucket	°	177	177	183	183	173	173	173

## Ground pressure

**EC380DHR Demolition mode; fixed undercarriage, with 10.55 m base boom + demo. boom, 2.5 m inter. arm, 6.7 m demolition arm, 2 500 kg crusher, 10 000 kg counterweight**

Description	Shoe width. mm	Operating weight. kg	Ground pressure. kPa	Overall width. mm
Triple grouser	600	46 835	83.5	3 980
	700	47 275	72.3	4 080
	800	47 720	63.8	4 180
	900	48 160	57.3	4 280
Double grouser	600	47 075	83.9	3 980

**EC380DHR Demolition mode; hydraulically retractable undercarriage, with 10.55 m base boom + demo. boom, 2.5 m inter. arm, 6.7 m demolition arm, 3 000 kg crusher, 10 000 kg counterweight**

Triple grouser	600	51 405	91.7	3 980
	700	51 845	79.2	4 080
	800	52 290	69.2	4 180
	900	52 730	62.7	4 280
Double grouser	600	51 645	92.1	3 980

**EC480DHR Demolition mode; fixed undercarriage, with 14.80 m base boom + demo. boom, 2.5 m inter. arm, 8.5 m demolition arm, 2 500 kg crusher, 13 000 kg counterweight**

Triple grouser	600	57 395	99.2	3 340
	700	57 895	85.8	3 440
	800	58 400	75.7	3 540
	900	58 900	67.9	3 640
Double grouser	600	57 445	99.3	3 340

**EC480DHR Demolition mode; fixed undercarriage, with 14.80 m base boom + demo. boom, 2.5 m inter. arm, 8.5 m demolition arm, 2 500 kg crusher, 13 000 kg counterweight**

Triple grouser	600	58 380	100.5	3 340
	700	58 880	86.9	3 440
	800	59 385	76.7	3 540
	900	59 885	68.7	3 640
Double grouser	600	58 430	100.6	3 340

**EC480DHR Demolition mode; hydraulically retractable undercarriage, with 14.80 m base boom + demo. boom, 2.5 m inter. arm, 8.5 m demolition arm, 3 000 kg crusher, 13000 kg counterweight**

Triple grouser	600	63 770	109.6	3 980
	700	64 270	94.7	4 080
	800	64 775	83.5	4 180
	900	65 275	74.8	4 280
Double grouser	600	63 820	109.7	3 980

**EC700CHR Demolition mode; mechanically retractable undercarriage, with 14.7 m base boom + demo. boom, 2.6 m inter. arm, 10 m demolition arm, 2 500 kg crusher, 15 250 kg counterweight**

Double grouser	650	79 685	115.8	4 390
	750	80 085	100.9	4 490
	900	81 425	85.5	4 640

**EC700CHR Demolition mode - 3 piece; hydraulically retractable undercarriage, with 14.7 m base boom + demo. boom, 2.6 m inter. arm, 10 m demolition arm, 3 500 kg crusher, 15 250 kg counterweight**

Double grouser	650	88 320	128.4	4 390
	750	88 720	111.8	4 490
	900	90 060	94.5	4 640

**EC700CHR Demolition mode - 4 piece; hydraulically retractable undercarriage, with 17.7 m base boom + demo. boom, 2.6 m inter. arm, 10 m demolition arm, 2 500 kg crusher, 15 250 kg counterweight**

Double grouser	650	90 910	132.1	4 390
	750	91 610	115.4	4 490
	900	92 650	97.3	4 640

# SPECIFICATIONS.

## DIMENSIONS

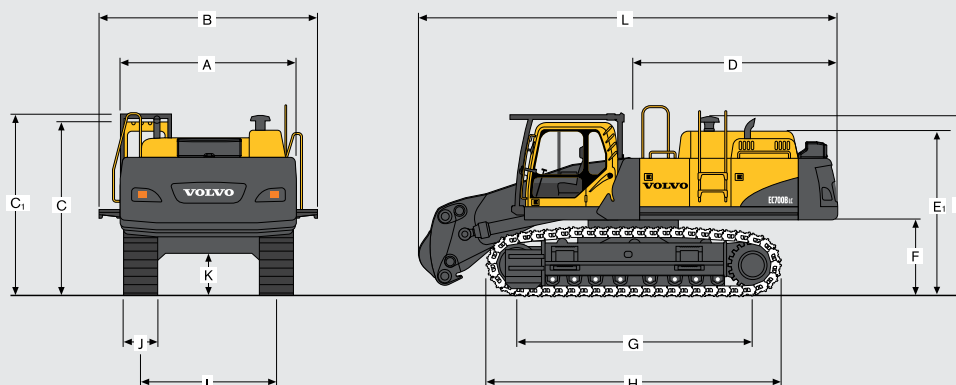

Description	Unit	EC380DHR		EC480DHR			EC700CHR		
		Undercarriage fixed (Standard)	Undercarriage hydraulically retractable	Undercarriage fixed (Standard)	Undercarriage mechanically retractable	Undercarriage hydraulically retractable	Undercarriage mechanically retractable (Standard)	Undercarriage hydraulically retractable	
A	Width superstructure	mm	2 990	2 990	2 990	2 990	2 990	3 420	3 420
B	Overall width with walk way (only left side)	mm	3 320	3 320	3 320	3 320	3 320	4 286	4 286
	Overall width with SIPS (both sides) & Cab entrance step (left hand side)	mm	3 415	3 415	3 415	3 415	3 415	-	-
	Overall width with SIPS (both sides) & Cab entrance step (left hand side), removed	mm	2 990	2 990	2 990	2 990	2 990	-	-
C	Overall height	mm	3 270	3 270	3 280	3 390	3 390	3 520	3 520
C1	Overall height (including FOG)	mm	3 380	3 380	3 390	3 500	3 500	3 620	3 620
D	Tail swing radius	mm	3 590	3 590	3 880	3 880	3 880	4 090	4 090
E	Overall height of engine hood	mm	2 930	2 930	2 930	3 040	3 040	3 310	3 310
E1	Overall height of diffuser	mm	3 410	3 410	3 425	3 535	3 535	3 590	3 590
F	Minimum counterweight clearance*	mm	1 260	1 260	1 255	1 365	1 365	1 507	1 507
G	Tumbler length	mm	4 240	4 240	4 370	4 370	4 370	4 750	4 750
H	Track length	mm	5 180	5 210	5 370	5 370	5 370	5 990	5 990
I	Track gauge (extended)	mm	2 740	3 380	2 740	2 890	3 380	3 350	3 740
	Track gauge (retracted)	mm	-	2 390	-	2 390	2 390	2 750	2 750
J	Shoe width	mm	600	600	600	600	600	650	650
K	Minimum ground clearance*	mm	500	480	550	745	485	858	625
L	Overall length	mm	7 060	7 060	7 535	7 535	7 535	8 380	8 380
	Total weight without additional counterweight	kg	35 040	39 110	42 330	43 315	48 205	60 995	68 590

\* Without shoe grouser

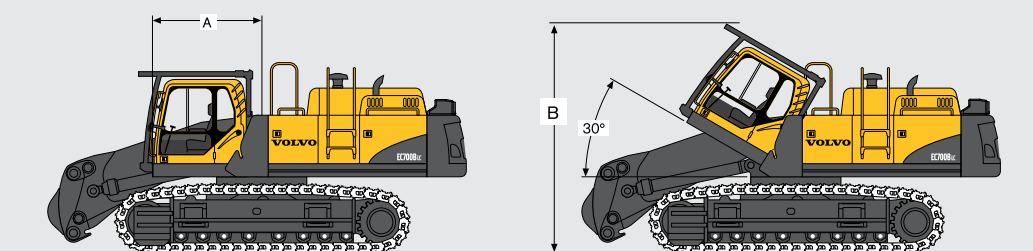

### Dimensions of basic demolition machines

	Unit	Undercarriage fixed (Standard)	Undercarriage hydraulically retractable	Undercarriage fixed (Standard)	Undercarriage mechanically retractable	Undercarriage hydraulically retractable	Undercarriage mechanically retractable (Standard)	Undercarriage hydraulically retractable
Tilting cab length	mm	2 175	2 175	2 175	2 175	2 175	2 015	2 015
Cabin height when fully tilted	mm	4 160	4 200	4 240	4 350	4 350	4 200	4 200
Cab tilting angle	°	30	30	30	30	30	30	30

# VOLVO EC380DHR, EC480DHR, EC700CHR IN DETAIL.

## Tilting Cab

The standard hydraulically tilting cabin tilts up to 30 degrees to enhance visibility and reduce operator fatigue and neck strain on high-reach jobs.

The operator's cab has easy access via a wide door opening. The cab is supported on hydraulic dampening mounts to reduce shock and vibration levels. These along with sound absorbing lining provide low noise levels. The cab has excellent all-round visibility.

The front windshield can easily slide up into the ceiling, and the lower front glass can be removed and stored in the side door.

Integrated air-conditioning and heating system: The pressurized and filtered cab air is supplied by an automatically-controlled fan. The air is distributed throughout the cab from 14 vents.

Ergonomic operator's seat: The adjustable seat and joystick console move independently to accommodate the operator.

The seat has nine different adjustments plus a seat belt for the operator's comfort and safety.

## Sound Level

		EC380DHR	EC480DHR	EC700CHR
Sound level in cab according to ISO 6396				
LpA	dB(A)	71	71	72
External sound level according to ISO 6395 and				
EU Noise Directive (2000/14/EC) and 474-1:2006 +A1:2009				
LwA	dB(A)	105	106	107

## Digging Equipment

		EC380DHR	EC480DHR	EC700CHR
Arm with strip	m	3.20	3.35	2.90
Arm without strip	m	3.20	3.35	-
Arm with strip	m	3.90	3.90	3.55
Arm without strip	m	3.90	3.90	-
Arm with strip	m	-	-	4.20

## Machine Weights

### EC380DHR

At Demolition Equipment

	mm	Fixed undercarriage	Hydraulically retracted undercarriage
(Condition shoe for EU region)			600
Base machine	Kg	34 600	38 670
3-piece demolition equipment (incl cradle)	Kg	6 425	6 425
Boom extension	Kg	NO	NO
Additional CWT	Kg	3 800	3 800
<b>Total weight</b>	<b>kg</b>	<b>44 825</b>	<b>48 895</b>

At Digging Equipment

Base machine	Kg	34 600	38 670
Digging equipment with 3,35m arm (incl cradle)	Kg	5 320	5 320
<b>Total weight</b>	<b>Kg</b>	<b>39 920</b>	<b>43 990</b>

### EC480DHR

At Demolition Equipment

	mm	Fixed undercarriage	Mech. retracted undercarriage	Hydr. retracted undercarriage
(Condition shoe for EU region)				600
Base machine	Kg	42 185	43 145	48 785
3-piece demolition equipment (incl cradle)	Kg	9 465	9 465	9 465
Boom extension	Kg	NO	NO	NO
Additional CWT	Kg	3 800	3 800	3 800
<b>Total weight</b>	<b>kg</b>	<b>55 450</b>	<b>56 410</b>	<b>62 050</b>

At Digging Equipment

Base machine	Kg	42 185	43 145	48 785
Digging equipment with 3,35m arm (incl cradle)	Kg	6 495	6 495	6 495
<b>Total weight</b>	<b>Kg</b>	<b>48 680</b>	<b>49 640</b>	<b>55 280</b>

### EC700CHR

At Demolition Equipment

	mm	Mech. retracted undercarriage	Hydr. retracted undercarriage
(Condition shoe for EU region)			650
Base machine	Kg	60 955	68 590
3-piece demolition equipment (incl cradle)	Kg	12 310	12 310
Boom extension	Kg	3 590	3 590
Additional CWT	Kg	4 500	4 500
<b>Total weight</b>	<b>kg</b>	<b>81 355</b>	<b>88 990</b>

At Digging Equipment

Base machine	Kg	60 955	68 590
Digging equipment with 3,35m arm (incl cradle)	Kg	10 075	10 075
<b>Total weight</b>	<b>Kg</b>	<b>71 030</b>	<b>78 665</b>

## Hydraulic system

The hydraulic system, also known as the "Automatic Sensing Work Mode," is designed for high-productivity, high-digging capacity, high-maneuvering precision and excellent fuel economy. The summation system, boom, arm and swing priority along with boom and arm regeneration provides optimum performance. The following important functions are included in the system:

**Summation system:** Combines the flow of both hydraulic pumps to a single function to ensure quick cycle times and high productivity.

**Boom priority:** Gives priority to the boom operation for faster raising when loading or performing deep excavations.

**Arm priority:** Gives priority to the arm operation for faster cycle times in leveling and for increased bucket filling when digging.

**Swing priority:** Gives priority to swing functions for faster simultaneous operations.

**Regeneration system:** Prevents cavitation and provides flow to other movements during simultaneous operations for maximum productivity.

**Power boost:** All digging and lifting forces are increased.

**Holding valves:** Boom and arm holding valves prevent the digging equipment from creeping.

	EC380DHR	EC480DHR	EC700CHR
Main pump, Type 2 x variable displacement axial piston pumps			
Maximum flow l/min	2 x 300	2 x 358	2 x 436
Pilot pump, Type Gear pump			
Maximum flow l/min	25.5	32	27.4

## Hydraulic motors

**Travel:** Variable displacement axial piston motor with mechanical brake

**Slew:** Fixed displacement axial piston motor with mechanical brake

**Relief valve setting**

		EC380DHR	EC480DHR	EC700CHR
Implement	MPa	32.4/35.3	32.4/35.3	31.4/34.3
Travel circuit	MPa	35.3	32.4	34.3
Slew circuit	MPa	27.9	25.8	25.5
Pilot circuit	MPa	3.9	3.9	3.9

## Hydraulic cylinders

		EC380DHR	EC480DHR	EC700CHR
Mono boom		2	2	2
Bore x Stroke	ø x mm	160 x 1530	165 x 1590	190 x 1790
Arm	1	1	1	1
Bore x Stroke	ø x mm	175 x 1750	190 x 1850	215 x 2070
Bucket	1	1	1	1
Bore x Stroke	ø x mm	145 x 1285	165 x 1330	190 x 1450
ME Bucket	1	1	1	1
Bore x Stroke	ø x mm	160 x 1250	175 x 1335	200 x 1450

## Service refill capacities

Fuel tank	l	620	685	840
Hydraulic system, total	l	500	525	655
Hydraulic tank	l	220	270	350
Engine oil	l	42	42	52
Engine coolant	l	60	60	65
Slew reduction unit	l	6,5	2 x 6	2 x 6
Travel reduction unit	l	2 x 6,8	2 x 8	2 x 20

## Hydraulic cylinder for Demolition EC380DHR

	Qty	Bore ø mm	Stroke mm
<b>for Demolition</b>			
Base boom cylinder	2	160	1 530
Intermediate arm cylinder	1	160	1 530
Demolition arm cylinder	1	150	1 745
Crusher arm cylinder	2	130	1 150

## for Digging

Base boom cylinder	2	160	1 530
Arm cylinder	1	175	1 700
Bucket cylinder	1	145	1 285

## for HR

Modular cylinder	2	100	545
Tilting cab cylinder	2	65	130
Hyd. Retractable U/C cylinder	2	140	1 000

## Hydraulic cylinder for Demolition EC480DHR

	Qty	Bore ø mm	Stroke mm
<b>for Demolition</b>			
Base boom cylinder	2	175	1 590
Intermediate arm cylinder	1	175	1 700
Demolition arm cylinder	1	175	1 700
Crusher arm cylinder	1	130	1 150

## for Digging

Base boom cylinder	2	175	1 590
Arm cylinder	1	190	1 850
Bucket cylinder	1	165	1 335

## for HR

Modular cylinder	2	100	590
Tilting cab cylinder	2	65	130
Hyd. Retractable U/C cylinder	2	140	1 000

## Hydraulic cylinder for Demolition EC700CHR

	Qty	Bore ø mm	Stroke mm
<b>for Demolition</b>			
Base boom cylinder	2	200	1 790
Intermediate arm cylinder	1	215	2 070
Demolition arm cylinder	1	190	1 850
Crusher arm cylinder	1	140	1 140

## for Digging

Base boom cylinder	2	200	1 790
Arm cylinder	1	215	2 070
Bucket cylinder	1	190	1 450

## for HR

Modular cylinder	2	100	590
Tilting cab cylinder	2	65	130
Hyd. Retractable U/C cylinder	2	140	1 000